

ODS 115

Standard & 2 kHz Model

Optical Displacement Sensor
Using Advanced Laser Technique,
A line Scan Camera And Digital
Signal Processing.



Specifications

Measurement data

Measuring range	100-130 mm
Center distance	115 mm
Resolution	0,002 mm
Reproducibility	± 0,002 mm
Linearity	±0.1% of Full Scale
Updating frequency	1000/500 Hz or 2/1 kHz
Temperature deviation	± 0.03% of FS/°C
Light source	Visible laser (670nm)
Size of light spot	Ø 1 mm
Laser protection class	IEC 2

Output data

Voltage output	(1-9 VDC)
Current output	4-20 mA
Digital output	RS232C or RS422/485
Baud rate	38400 or 115200

Environment data

Operating temperature	0 - +45 °C
Storage temperature	-20 - +70 °C
Humidity (non condensing)	Max 90 % RH
Degree of protection	IEC IP65

Physical data

Dimensions	136*146*50 mm
Weight excl. Cable	1600 g
Cable length	2.5 m
Housing	Steel / Aluminium

Electrical data

Supply voltage	24 VDC ± 10 %
Power consumption, max	4.5 W

Specifications subject to change without notice

Dimensions

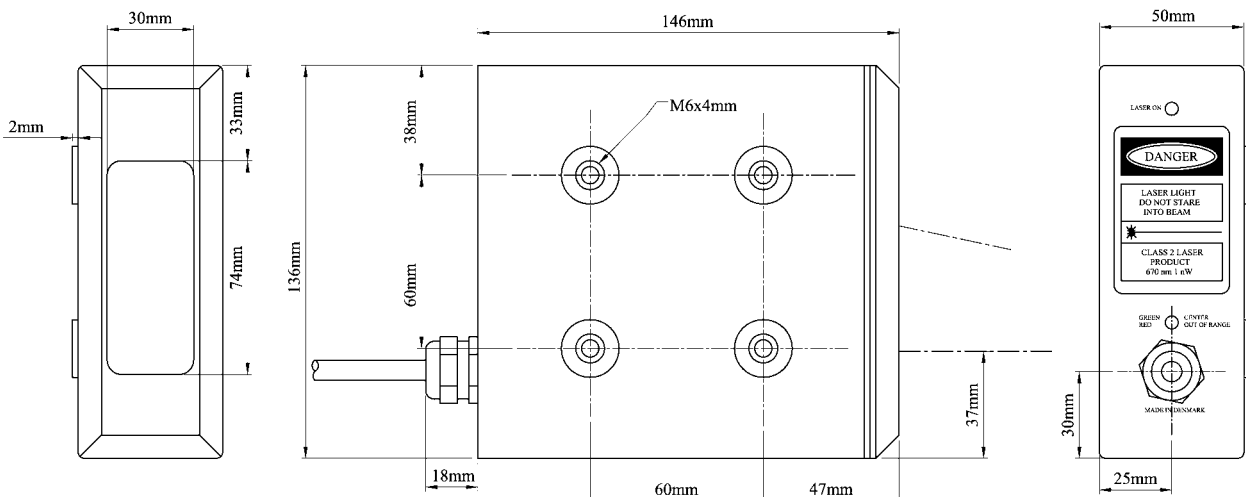

General description

The ODS 115 sensor is an optical measuring device for contactless precision measurement of distance or thickness. The measurement is performed by means of the triangulation principle. A focused laser beam forms a spot on the object. The image is recorded by a CCD-camera, making possible a calculation of the distance to the object.

The ODS 115 measuring system is a compact unit in which optics, sensor, and signal processing electronics are integrated. The sensor is easy to install, since two light emitting diodes indicate, when the object is at the centre or outside the measuring range. Furthermore, the laser light is visible and therefore easy to see on the object.

The sensor is delivered with a demo disk containing a program for a standard IBM-PC. The program receives data from the ODS 115 and displays the measured distance on the screen.

The ODS 115 has a very broad range of applications. The sensor is very well suited for measurement on surfaces where other sensor types, e.g. inductive or capacitive, must give up. Especially on wood, plastic, rubber, and paper products the sensor is useful, but it can also be used on most metals and liquids.

Because of the non-contact measurement method, the sensor is especially useful for measurement on soft materials as foam rubber and food products.

The ODS 115 is designed to give a very high measuring accuracy. The measured data is available on the RS232 output with a resolution of $2\mu\text{m}$ as well as on the two analog outputs with a resolution with a resolution of $2\mu\text{m}$.

Applications

Typical applications of the ODS 115 sensor is

- Distance measurement
- Thickness measurement
- Profile measurement
- Level control
- Control of vacuum in containers
- Control of surface treatments
- Measurements for feedback in productions lines
- Measurements for quality control and statistics

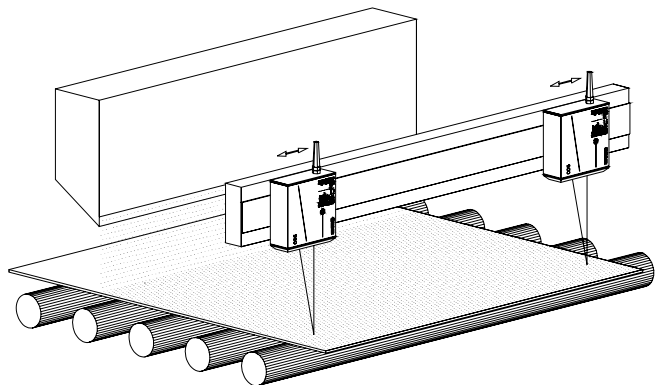

At the right, an application is shown where the sensor is used for thickness control and feedback in the production of roofing felt.



Danish Sensor Engineering

DSE ApS · Columbusvej 3 · DK-2860 Søborg
Phone +45 39 66 71 44 · Fax +4539 66 71 45